

Hollo-Bolt® by Lindapter®

Installation is quickly carried out by inserting into pre-drilled steelwork and tightening with a torque wrench. Independent approvals include CE Mark, DIBt, TÜV and ICC-ES seismic accreditation.

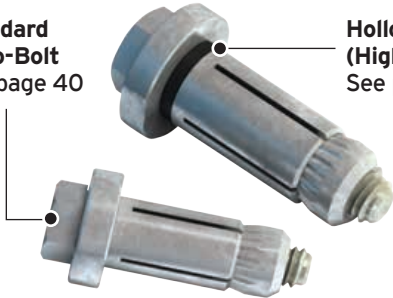

Standard Hollo-Bolt
See page 40



Hollo-Bolt HCF (High Clamping Force)
See pages 40 and 41

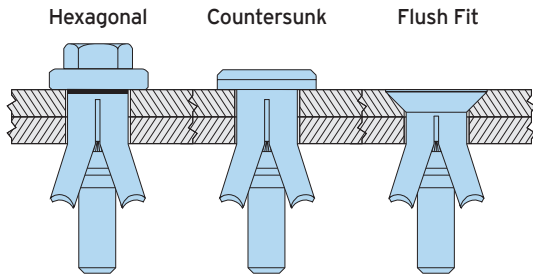

- Fast, cost saving installation from one side.
- For square, rectangular and circular hollow sections.
- High resistance to shear and tension.
- Patented High Clamping Force design.
- A range of head types for architectural finishes.
- CE Mark, DIBt, TÜV and ICC-ES Seismic approvals.

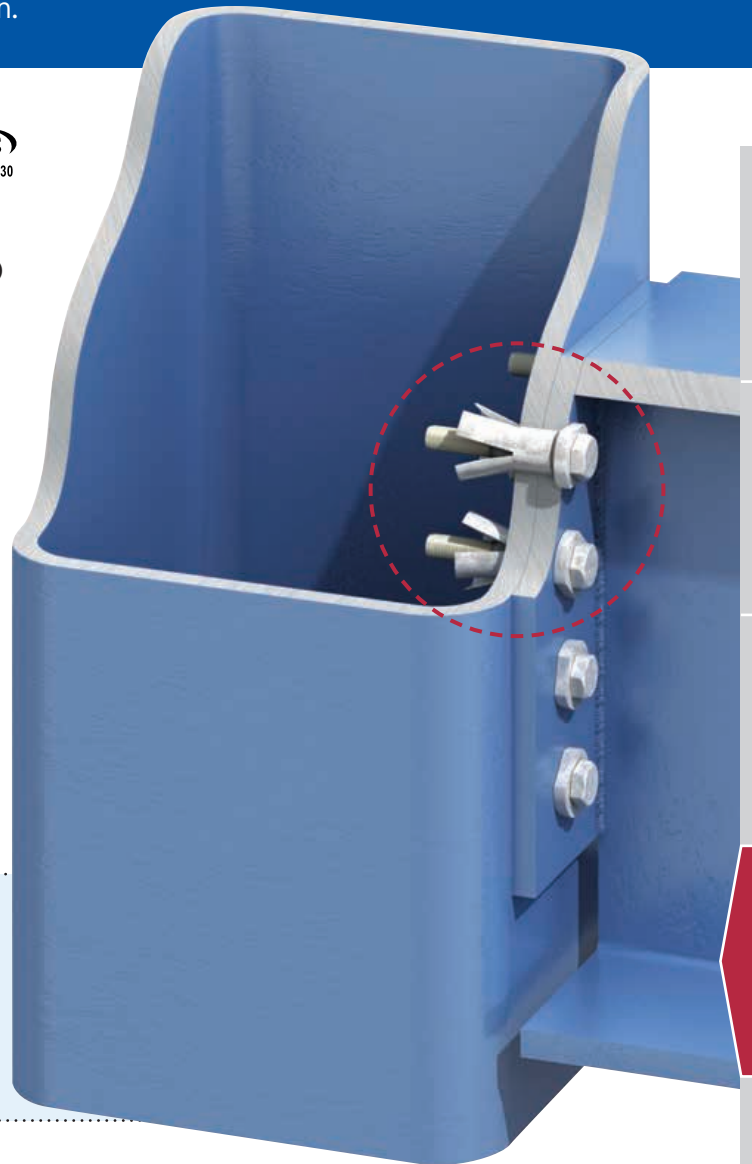

Hollo-Bolt head variant comparison

Head variants	Sizes					Corrosion protection			
	M8	M10	M12	M16 HCF*	M20 HCF*	JS500	Hot Dip Galv.	Sheraplex	Stainless Steel
Hexagonal Normal visible protrusion	✓	✓	✓	✓	✓	✓	✓	✓	✓
Countersunk Minimal visible protrusion	✓	✓	✓	✓	-	✓	-	✓	✓
Flush Fit Zero visible protrusion	✓	✓	✓	-	-	✓	-	✓	✓

Lindapter can also manufacture customised products for specific connection requirements, e.g. security / button head and special sizes.



* Sizes M16 and M20, known as the Hollo-Bolt (HCF), feature a High Clamping Force mechanism to produce three times more clamping force than the same sized product without the mechanism. Turn to **pages 40 and 41** to see the significance of clamping force and the superior performance of this unique product.

Hollo-Bolt High Clamping Force

Lindapter Hollo-Bolts are available in two versions; the original standard design for general hollow section connections and larger sized High Clamping Force (HCF) for higher strength structural connections.

SIZES M8, M10 AND M12

Standard Hollo-Bolt

A typical connection is made by inserting the Hollo-Bolt into the pre-drilled holes of the fixture and hollow section. As the bolt head is tightened, the cone is pulled up the bolt thread, causing the sleeve to expand until the cone locks the sleeve against the hollow section's inner wall.

At full tightening torque, a clamping force is established between the fixture and the steel section to form a secure connection. Once installed, only the head and collar are visible.

→ ← = Clamping Force

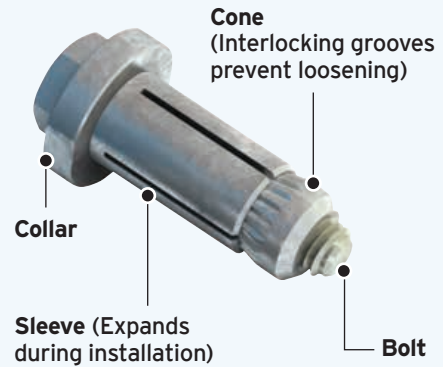
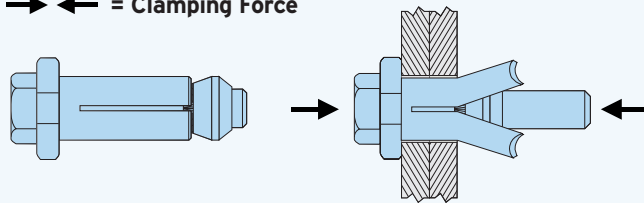

See how to install the Hollo-Bolt on page 44 or watch the video at www.Lindapter.com



SIZES M16 AND M20

Hollo-Bolt HCF

By working closely with Structural Engineers and Steel Fabricators, Lindapter identified the need for the larger M16 and M20 Hollo-Bolts to have an increased clamping force suitable for higher strength structural connections. This led to Lindapter's invention of the High Clamping Force (HCF) design, optimised for superior performance.

The HCF mechanism consists of a special rubber washer that compresses during installation to significantly increase the clamping force between the connecting steelwork, when compared to a product of the same size without the mechanism, thereby reducing displacement.

→ ← = Clamping Force

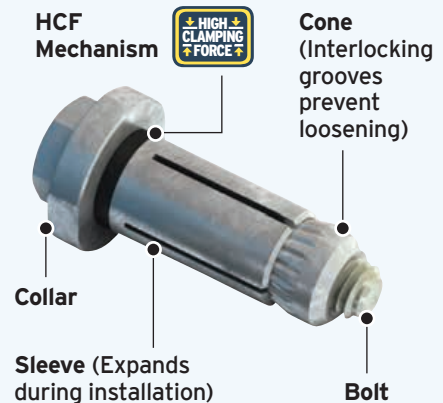
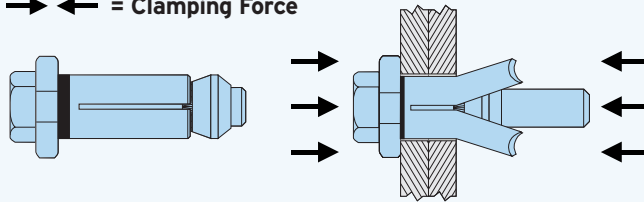

See how to install the Hollo-Bolt on page 44 or watch the video at www.Lindapter.com



GIRDER CLAMPS
RAIL FIXINGS
LIFTING POINTS
HOLLO-BOLT
FLOOR FIXINGS
SUPPORT FIXINGS
DECKING FIXINGS

Hollo-Bolt Clamping Force

Hollo-Bolts are optimised for structural connections and the larger M16 and M20 sizes feature a High Clamping Force (HCF) mechanism. The graphs below compare the performance of a Hollo-Bolt HCF and an expansion bolt of the same size without the mechanism.

Clamping Force Typical Performance Increase



M16: Up to 3 times more clamping force

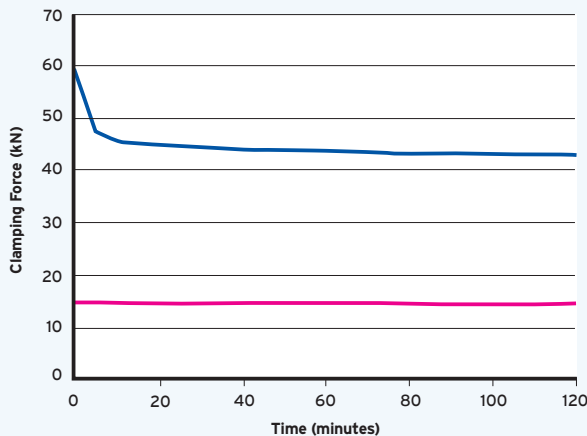

M20: Up to 3.5 times more clamping force

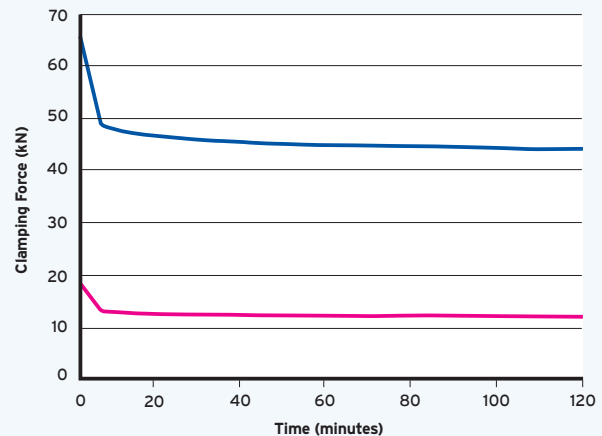

As with any structural bolt, immediately after installation the bolt relaxes until a typical clamping force is reached. The typical clamping force of the Hollo-Bolt (HCF) is over **three times higher** than the same sized product without the HCF mechanism. This results in a more secure connection and a greater force that has to be overcome before displacement begins.

Displacement Typical Performance Increase

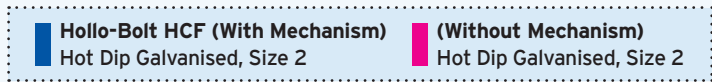

M16: Connection Load vs Ply Displacement

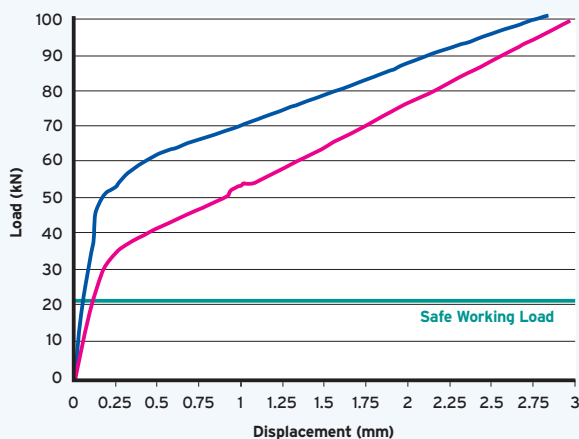

M20: Connection Load vs Ply Displacement

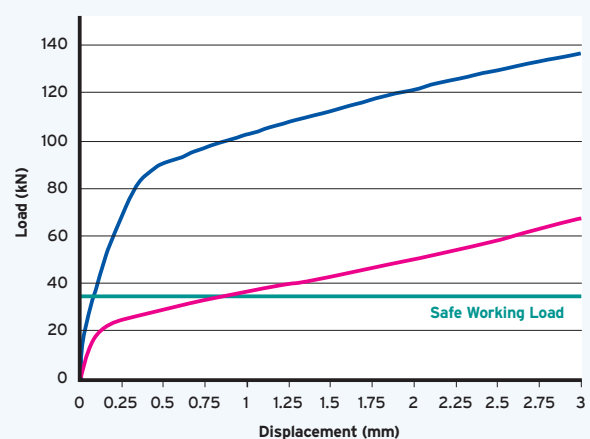

The graphs above show the significance of increased clamping force. The blue curve demonstrates the superior performance of the Hollo-Bolt HCF in contrast to M16 and M20 sized products without Lindapter's patented mechanism. At Safe Working Load, displacement (movement in the connection) is minimised when using the Hollo-Bolt HCF for a safer and more secure connection.

➤ Graphs for illustration purposes only, see page 42 and 43 for connection design.

Holo-Bolt Safe Working Loads

The Holo-Bolt is featured in the BCSA and SCI design guide 'Joints in Steel Construction - Simple Connections', please refer to this guide for designing primary structural connections. For connections to secondary steelwork, please refer to the tables below.

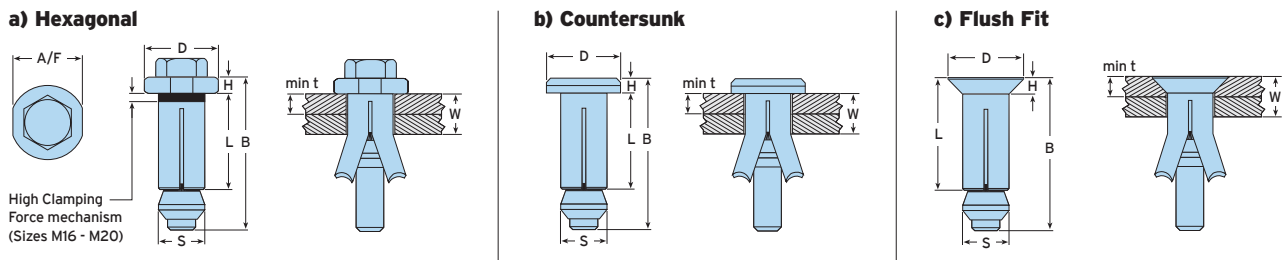

Product Code	a) Hexagonal		b) Countersunk		Clamping Thickness W mm	Outer Ply min t mm	Sleeve		Collar			Tightening Torque Nm	Safe Working Loads (5:1 Factor of Safety)	
	Bolt Length B mm	Product Code	Bolt Length B mm	Product Code			Length L mm	Outer Ø S mm	Height H mm	Ø D mm	A/F mm		Tensile kN	Single Shear kN
HB08-1	M8 x 50	HBCSK08-1	M8 x 50	HBCSK08-1	3 - 22	-	30	13.75	5	22	19	23	4.0	5.0
HB08-2	M8 x 70	HBCSK08-2	M8 x 70	HBCSK08-2	22 - 41	-	49	13.75	5	22	19	23	4.0	5.0
HB08-3	M8 x 90	HBCSK08-3	M8 x 90	HBCSK08-3	41 - 60	-	68	13.75	5	22	19	23	4.0	5.0
HB10-1	M10 x 55	HBCSK10-1	M10 x 50	HBCSK10-1	3 - 22	-	30	17.75	6	29	24	45	8.5	10.0
HB10-2	M10 x 70	HBCSK10-2	M10 x 70	HBCSK10-2	22 - 41	-	48	17.75	6	29	24	45	8.5	10.0
HB10-3	M10 x 90	HBCSK10-3	M10 x 90	HBCSK10-3	41 - 60	-	67	17.75	6	29	24	45	8.5	10.0
HB12-1	M12 x 60	HBCSK12-1	M12 x 55	HBCSK12-1	3 - 25	-	35	19.75	7	32	30	80	10.5	15.0
HB12-2	M12 x 80	HBCSK12-2	M12 x 80	HBCSK12-2	25 - 47	-	57	19.75	7	32	30	80	10.5	15.0
HB12-3	M12 x 100	HBCSK12-3	M12 x 100	HBCSK12-3	47 - 69	-	79	19.75	7	32	30	80	10.5	15.0
HB16-1	M16 x 75	HBCSK16-1	M16 x 70	HBCSK16-1	12 - 29	8	41.5	25.75	8	38	36	190	21.0	30.0
HB16-2	M16 x 100	HBCSK16-2	M16 x 100	HBCSK16-2	29 - 50	8	63	25.75	8	38	36	190	21.0	30.0
HB16-3	M16 x 120	HBCSK16-3	M16 x 120	HBCSK16-3	50 - 71	8	84	25.75	8	38	36	190	21.0	30.0
HB20-1	M20 x 90	-	-	-	12 - 34	8	50	32.75	10	51	46	300	35.0	40.0
HB20-2	M20 x 120	-	-	-	34 - 60	8	76	32.75	10	51	46	300	35.0	40.0
HB20-3	M20 x 150	-	-	-	60 - 86	8	102	32.75	10	51	46	300	35.0	40.0



Sizes M16 and M20, known as the Holo-Bolt (HCF), feature a High Clamping Force mechanism to produce three times more clamping force than the same sized product without the mechanism. Turn to pages 40 and 41 to see the significance of clamping force and the superior performance of this unique product.

Product Code	c) Flush Fit		Clamping Thickness W mm	Outer Ply min t mm	Sleeve		Collar			Tightening Torque Nm	Safe Working Loads (5:1 Factor of Safety)	
	Countersunk Bolt B mm	Product Code			Length L mm	Outer Ø S mm	Height H mm	Ø D mm	Installation Nut A/F mm		Tensile kN	Single Shear kN
HBFF08-1	M8 x 50	HBCSK08-1	10 - 27	8	35	13.75	5	24	19	23	4.0	5.0
HBFF08-2	M8 x 70	HBCSK08-2	27 - 45	8	54	13.75	5	24	19	23	4.0	5.0
HBFF08-3	M8 x 90	HBCSK08-3	45 - 64	8	73	13.75	5	24	19	23	4.0	5.0
HBFF10-1	M10 x 50	HBCSK10-1	12 - 27	10	36	17.75	6	30	24	45	8.5	10.0
HBFF10-2	M10 x 70	HBCSK10-2	27 - 45	10	54	17.75	6	30	24	45	8.5	10.0
HBFF10-3	M10 x 90	HBCSK10-3	45 - 64	10	73	17.75	6	30	24	45	8.5	10.0
HBFF12-1	M12 x 55	HBCSK12-1	12 - 30	10	42	19.75	7	33	30	80	10.5	15.0
HBFF12-2	M12 x 80	HBCSK12-2	30 - 52	10	64	19.75	7	33	30	80	10.5	15.0
HBFF12-3	M12 x 100	HBCSK12-3	52 - 74	10	86	19.75	7	33	30	80	10.5	15.0

Holo-Bolts can be used on a wide variety of steel hollow shape sections. Safe working loads shown are based on use in S275 structural hollow section and are applicable to the Holo-Bolt only in both tension and shear. Failure of the section, particularly on those with thin walls and a wide chord face, could occur at a lower figure and its strength should be checked by a qualified Structural Engineer.

Published by the SCI/BCSA Connections Group, 'Joints in Steel Construction - Simple Connections' provides design guidance for using Holo-Bolt and structural steelwork connections in buildings designed using the 'Simple Method' i.e. braced frames where connections carry mainly shear and axial loads only. For more information please contact The Steel Construction Institute on +44 (0) 1344 636525 or visit www.steel-sci.com



GIRDER CLAMPS
RAIL FIXINGS
LIFTING POINTS
HOLLO-BOLT
FLOOR FIXINGS
SUPPORT FIXINGS
DECKING FIXINGS

Hollo-Bolt Characteristic Values

The values listed in the tables below (taken from ETA-10/0416) are to be used when designing bolted connections to Eurocode 3 only, they are **not** standard safe working loads. Download the Declaration of Performance (DoP) at www.Lindapter.com/About/CE



Hollo-Bolt Hexagonal

	Product Code	Nominal Size	Tensile $F_{t,Rk}$ kN	Shear $F_{v,Rk}$ kN	Sleeve Material Strength N/mm ²
	HB08	M8	23.1	32.9	430
	HB10	M10	39.6	54.2	430
	HB12	M12	45.8	71.0	430
HCF	HB16	M16	84.3	139.0	430
HCF	HB20	M20	124.0	211.0	390

Hollo-Bolt Hexagonal Stainless Steel

	Product Code	Nominal Size	Tensile $F_{t,Rk}$ kN	Shear $F_{v,Rk}$ kN	Sleeve Material Strength N/mm ²
	HBST08	M8	26.8	30.7	500
	HBST10	M10	46.0	51.0	500
	HBST12	M12	53.3	65.0	500
HCF	HBST16	M16	98.0	128.0	500
HCF	HBST20	M20	154.0	205.0	500

Hollo-Bolt Countersunk

	Product Code	Nominal Size	Tensile $F_{t,Rk}$ kN	Shear $F_{v,Rk}$ kN	Sleeve Material Strength N/mm ²
	HBCSK08	M8	23.1	32.9	430
	HBCSK10	M10	39.6	54.2	430
	HBCSK12	M12	45.8	71.0	430
HCF	HBCSK16	M16	84.3	139.0	430

Hollo-Bolt Countersunk Stainless Steel

	Product Code	Nominal Size	Tensile $F_{t,Rk}$ kN	Shear $F_{v,Rk}$ kN	Sleeve Material Strength N/mm ²
	HBSTCSK08	M8	26.8	30.7	500
	HBSTCSK10	M10	46.0	51.0	500
	HBSTCSK12	M12	53.3	65.0	500
HCF	HBSTCSK16	M16	98.0	128.0	500



Sizes M16 and M20, known as the Hollo-Bolt (HCF), feature a High Clamping Force mechanism to produce three times more clamping force than the same sized product without the mechanism. Turn to **pages 40 and 41** to see the significance of clamping force and the superior performance of this unique product.

Hollo-Bolt Flush Fit

	Product Code	Nominal Size	Tensile $F_{t,Rk}$ kN	Shear $F_{v,Rk}$ kN	Sleeve Material Strength N/mm ²
	HBFF08	M8	23.1	32.9	430
	HBFF10	M10	39.6	54.2	430
	HBFF12	M12	45.8	71.0	430

Hollo-Bolt Flush Fit Stainless Steel

	Product Code	Nominal Size	Tensile $F_{t,Rk}$ kN	Shear $F_{v,Rk}$ kN	Sleeve Material Strength N/mm ²
	HBSTFF08	M8	26.8	30.7	500
	HBSTFF10	M10	46.0	51.0	500
	HBSTFF12	M12	53.3	65.0	500

Hollo-Bolt lengths 1, 2 and 3 are covered by ETA 10/0416. The characteristic values are used to determine the design resistance of the Hollo-Bolt. The design resistance is calculated by dividing the characteristic value by a partial factor γ_{m2} . The partial factor is a nationally determined parameter (eg: $\gamma_{m2} = 1.25$ in UK).

For Hollo-Bolt safe working loads with a Factor of Safety of 5:1 please refer to the tables on **page 42** of this catalogue. The characteristic values are valid for the assembly itself, in any connection detail the design resistance of the connection may be limited to a lesser value. For example, when the thickness of the connected component is small, pull out failure may occur before failure of the Hollo-Bolt. Design checks should be carried out to determine the static design resistance.

The SCI Greenbook publication 'Joints in Steel Construction: Simple Joints to Eurocode 3' contains a number of checks on the section. The characteristic values are only valid when the Hollo-Bolts are installed as per Lindapter's installation instructions. For more information please contact The Steel Construction Institute on +44 (0) 1344 636525 or visit www.steel-sci.com



Holo-Bolt Preparation and Installation

Please ensure that the holes are drilled into both the fixture and the section according to the drilling guidance below. Please note that the holes are slightly larger than standard bolt clearance holes to accommodate the sleeve and cone.

Hexagonal and Countersunk

Type		Outer Ply min t mm	Clearance Hole Ø d1 mm	Hole Distances		Edge Distances B + C mm
Hex	Countersunk			min A mm	min B mm	
HB08	HBCSK08	-	14 (+1.0/-0.2)	35	13	> 17.5
HB10	HBCSK10	-	18 (+1.0/-0.2)	40	15	> 22.5
HB12	HBCSK12	-	20 (+1.0/-0.2)	50	18	> 25.0
HB16	HBCSK16	8	26 (+2.0/-0.2)	55	20	> 32.5
HB20	-	8	33 (+2.0/-0.2)	70	25	> 33.0

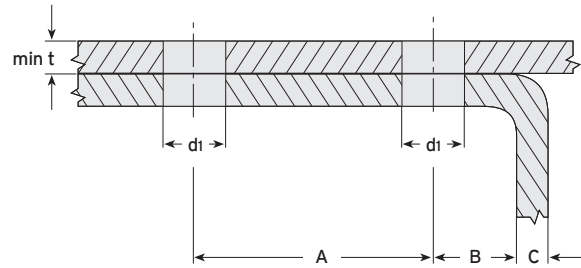

► Sizes M16 and M20 require outer ply thickness (min t) to be at least 8mm.



How to install...

- 1) Align pre-drilled fixture and section then insert the Holo-Bolt^{a)}.
- 2) Grip Holo-Bolt collar with an open ended spanner.
- 3) Using a calibrated torque wrench, tighten the central bolt to the recommended torque^{b)}.

▶ Watch the Holo-Bolt installation video at www.Lindapter.com

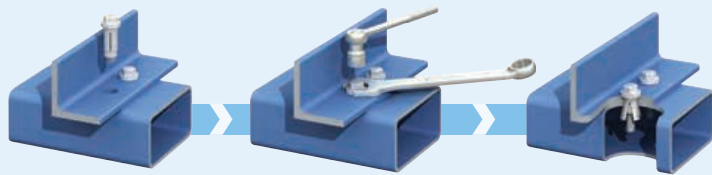

Flush Fit

Type	Outer Ply min t mm	Clearance Hole Ø d1 mm	Countersunk		Hole Distances		Edge Distances B + C mm
			d2 mm	t1 mm	min A mm	min B mm	
HBFF08	8	14 (+1.0/-0.2)	27	6.5	35	13	> 17.5
HBFF10	10	18 (+1.0/-0.2)	31	6.5	40	15	> 22.5
HBFF12	10	20 (+1.0/-0.2)	35	7.5	50	18	> 25.0

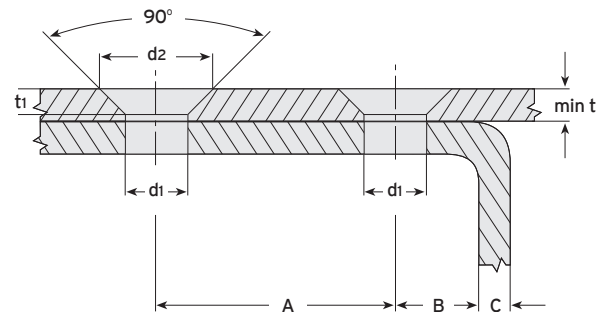

How to install...

- 1) Align pre-drilled fixture and section then insert the Holo-Bolt^{a)}.
- 2) Apply the installation nut and grip with an open ended spanner.
- 3) Using a calibrated torque wrench, tighten the central countersunk bolt to the recommended torque^{b)}.

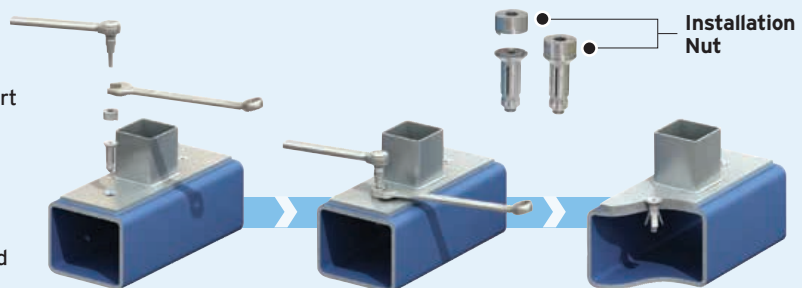

Notes:

- a) Before tightening, ensure that the materials that are to be connected together are touching. See page 42 for tightening torque.
- b) Power tools, such as an impact wrench, may be used to speed up the tightening of the Holo-Bolt. However, when using power tools, always complete the tightening process with a calibrated torque wrench to ensure the correct torque is applied to the Holo-Bolt.

GIRDER CLAMPS
RAIL FIXINGS
LIFTING POINTS
HOLLO-BOLT
FLOOR FIXINGS
SUPPORT FIXINGS
DECKING FIXINGS